



MADE IN ITALY



catalogo generale  
general catalog  
catalogue general  
allgemeiner Katalog  
общий каталог



MADE IN ITALY



## Quality since 1979

 **Aceti Macchine** progetta e produce macchine per la lavorazione e la finitura del metallo.

L'esperienza e le conoscenze del settore sviluppate con decenni di attività e con migliaia di macchine vendute, le permette di proporsi sul mercato europeo e mondiale come leader del settore.

Dal **1979** ad oggi vanta una vasta gamma con **oltre 100 modelli** tra cui: satinatrici, levigatrici per incavi, sbavalamiere, sbavatubi, smussatrici, levigatrici a nastro e a disco, pulitrici, smerigliatrici a mola, affilapunte, affilafrese, affilautensili, aspiratori per polveri. Tutti i modelli sono **prodotti interamente in Italia** presso il moderno stabilimento di Bolgare (Bergamo) nel cuore industriale della Lombardia. L'azienda è situata su un'area di 25.000 m<sup>2</sup> di cui 5.000 m<sup>2</sup> coperti adibiti alla progettazione, costruzione, assemblaggio, collaudo, vendita e assistenza.

 **Aceti Macchine** designs and manufactures machinery for metal processing and finishing.

Experience and knowledge developed over decades with the sale of thousands of machines positions the company as a leader in its sector both in Europe and around the world.

Since **1979 over 100 models** have been produced, including belt grinding machines for satin finishing, pipe notcher, deburring machines for metal sheets and tubes, bevelling machines, belt and disc grinding machines, polishing and buffing machines, grinding machines, drill sharpening machines, end mill sharpening machines, tool sharpening machines and dust extractors. All our products are **made entirely in Italy** at our modern premises in Bolgare (Bergamo), in the industrial heart of Lombardy. The company is located over an area of 25,000 square meters, including 5,000 sq.m. of covered space dedicated to design, manufacture, assembly, testing, sales and customer services.

 **Aceti Macchine** conçoit et produit des machines pour l'usinage et la finition du métal.

L'expérience et les connaissances du secteur développées au cours de dizaines d'années d'activité et avec des milliers de machines vendues lui permettent d'occuper la place de leader du secteur sur le marché européen et mondial.

Depuis **1979** jusqu'à aujourd'hui, elle se vante d'une large gamme avec **plus de 100 modèles** dont: machines à satiner, grugeuses de tubes, ébavureuses de tôles, ébavureuses de tubes, chanfreineuses, ponceuses à bande et à disque, polisseuses, tourets à meuler, affûteuses de forets, affûteuses de fraises, affûteuses d'outils, aspirateurs. Tous les modèles sont **entièrement produits en Italie** à l'usine moderne de Bolgare (Bergame) dans le cœur industriel de la Lombardie. L'entreprise se situe sur une zone de 25.000 m<sup>2</sup> dont 5.000 m<sup>2</sup> couverts destinés à la conception, à la fabrication, à l'assemblage, au test, à la vente et à l'assistance.

 **Aceti Macchine** entwickelt und produziert Maschinen zur Bearbeitung und Feinbearbeitung von Metall.

Dank der langjährigen Erfahrung, der Kenntnis der Branche und tausender verkaufter Maschinen konnte man sich als führendes Unternehmen auf dem europäischen, wie auch auf dem weltweiten Markt behaupten. Ab **1979** bis heute mit einer Produktpalette mit **über 100 Modellen**, wie: Satiniermaschinen, Rohrausschleifmaschinen, Blechentgratmaschinen, Rohrentgratmaschinen, Kantenfräsmaschinen, Band- und Tellerschleifmaschinen, Poliermaschinen, Scheibenschleifmaschinen, Bohrer- und Fräuserschleifmaschinen, Werkzeugschleifmaschinen, Staub-Absauganlagen. Alle Modelle werden **vollständig in Italien**, in dem hochmodernen Werk in Bolgare (Bergamo), dem industriellen Herzstück der Lombardei, gefertigt. Das Firmenareal ist 25.000 m<sup>2</sup> groß, 5.000 m<sup>2</sup> sind für die Entwicklung, die Fertigung, den Zusammenbau, Abnahme, Verkauf und den Kundendienst bestimmt.



A range of over  
**100** models



**OPTIONAL**

**INV.**

- Inverter per la regolazione elettronica da 0 a 3000 giri/min
- Inverter for the electronic adjustment from 0 to 3000 Rpm
- Variateur pour le réglage électronique de 0 à 3000 T/min
- Inverter für stufenlose elektronische Regulierung von 0 bis 3000 UpM



**OPTIONAL**  
**IA-2**







ART. 66		PULTRICE SINGOLA SINGLE POLISHING MACHINE POLISSOIR CHAQUE SCHLEIF-UND POLIERMASCHINE							
Volt 400 kW 1,8		E	F	G1	L	kg			
hp	Rpm	m/s	dB	E	F	G1	L	kg	
2,5	1400 2800	18 36	70	600	950	910	350	80	
NOT INCLUDED	OPTIONAL	OPTIONAL							
Ø mm	INVERTER	IA-1							
Ø250xØ25	Rpm 0÷3000	kW 0,55							



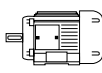
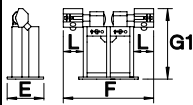

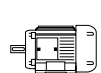

ART. 74		PULTRICE PROFESSIONAL SINGOLA PROFESS. SINGLE POLISHING MACHINE POLISSOIR PROFESSIONNEL CHAQUE SCHLEIF-UND POLIERMASCHINE							
Volt 400 kW 4,4		E	F	G1	L	kg			
hp	Rpm	m/s	dB	E	F	G1	L	kg	
6	1400 2800	22 44	70	600	950	890	370	90	
NOT INCLUDED	OPTIONAL	OPTIONAL							
Ø mm	Rpm	INVERTER		IA-1					
Ø300xØ35	700÷1400	Rpm 0÷3000		kW 0,55					

ART. 27		PULTRICE DOPPIA DOUBLE POLISHING MACHINE POLISSOIR ( 2 POSTES ) DOPPELSCHLEIF-UND POLIERMASCHINE							
Volt 400 kW 1,8		E	F	G1	L	kg			
hp	Rpm	m/s	dB	E	F	G1	L	kg	
2,5	1400 2800	18 36	70	600	1000	910	300	85	
NOT INCLUDED	OPTIONAL	OPTIONAL							
Ø mm	INVERTER	IA-2							
Ø250xØ25	Rpm 0÷3000	kW 0,55							

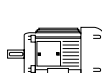
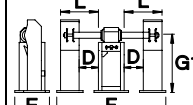



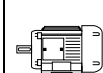
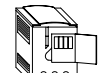

ART. 46		PULTRICE PROFESSIONAL DOPPIA PROFESS. DOUBLE POLISHING MACHINE POLISSOIR ( 2 POSTES ) PROFESSIONNEL DOPPELSCHLEIF-UND POLIERMASCHINE							
Volt 400 kW 4,4		E	F	G1	L	kg			
hp	Rpm	m/s	dB	E	F	G1	L	kg	
6	1400 2800	22 44	70	600	1050	890	320	105	
NOT INCLUDED	OPTIONAL	OPTIONAL							
Ø mm	Rpm	INVERTER		IA-2					
Ø300xØ35	700÷1400	Rpm 0÷3000		kW 0,55					

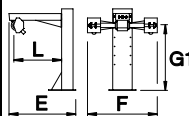

<b>ART. 71</b>		<b>PULTRICE PROFESSIONAL DOPPIA</b> PROFESSIONAL DOUBLE POLISHING MACHINE POLISSOIR ( 2 POSTES ) PROFESSIONNEL DOPPELSCHLEIF-UND POLIERMASCHINE													
															
Nr.2 Volt 400 kW 4,4		E F G1 L		dB		kg		NOT INCLUDED Ø mm		OPTIONAL Rpm		OPTIONAL INVERTER		OPTIONAL ASP.01	
hp	Rpm	m/s	E	F	G1	L	dB	kg	Ø mm	Rpm	INVERTER	ASP.01			
6	1400 2800	22 44	600	1600	890	350	70	250	Ø300xØ35	700÷1400	Rpm 0÷3000	kW 1,5			

<b>ART. 94</b>		<b>PULTRICE PROFESSIONAL DOPPIA</b> PROFESSIONAL DOUBLE POLISHING MACHINE POLISSOIR ( 2 POSTES ) PROFESSIONNEL DOPPELSCHLEIF-UND POLIERMASCHINE													
															
Volt 400 kW 5,5		E F G1 D L		dB		kg		NOT INCLUDED Ø mm		OPTIONAL Rpm		OPTIONAL INVERTER		OPTIONAL ASP.01	
hp	Rpm	m/s	E	F	G1	D	L	dB	kg	Ø mm	Rpm	INVERTER	ASP.01		
7,5	1400 2800	29 58	600	1700	890	300	590	70	265	Ø400xØ35	700÷1400	Rpm 0÷3000	kW 1,5		





<b>ART. 95</b>		<b>PULITRICE SOSPESA PROFESSIONAL</b> <b>PROFESSIONAL SUSPENDED POLISHING MACHINE</b> <b>POLISSOIR SUSPENDUE PROFESSIONNEL</b> <b>BERUFLICHE HÄNGEND POLIERMASCHINE</b>										
												
Volt 400 kW 5,5							kg	NOT INCLUDED	OPTIONAL	OPTIONAL	OPTIONAL	
hp	Rpm	m/s	E	F	G1	L	dB	kg	Ø mm	Rpm	INVERTER	ASP.01
7,5	1400 2800	29 58	1450	1050	430+1500	1000	70	425	Ø400xØ35	700+1400	Rpm 0+3000	kW 1,5





NOT INCLUDED

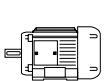
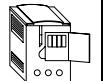
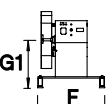
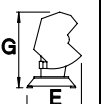

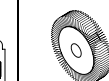
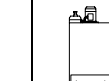
NOT INCLUDED

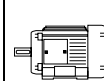
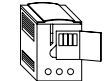
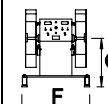
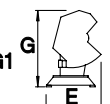

<b>ART. 139</b>		<b>PULITRICE PROFESSIONAL SINGOLA CON 1 INVERTER</b> <b>PROFESSIONAL SINGLE POLISHING MACHINE WITH 1 INVERTER</b> <b>POLISSOIR CHAQUE PROFESSIONNEL AVEC 1 VARIATEUR DE VITESSE</b> <b>SCHLEIF-UND POLIERMASCHINE MIT 1 FREQUENZUMRICHTER</b>								
										
INVERTER Nr.1 Volt 400 kW 5,5		E	F	G	G1	dB	kg	NOT INCLUDED	OPTIONAL	
hp	Rpm	E	F	G	G1	dB	kg	Ø mm	ASP.01	
7,5	0 + 1500	1460	1560	1600	1000	75	1050	Ø960 x 100 x Ø45	kW 3	

<b>ART. 140</b>		<b>PULITRICE PROFESSIONAL DOPPIA CON 2 INVERTER</b> <b>PROFESSIONAL DOUBLE POLISHING MACHINE WITH 2 INVERTERS</b> <b>POLISSOIR (2 POSTES) PROFESSIONNEL AVEC 2 VARIATEURS DE VITESSE</b> <b>DOPPELSCHLEIF-UND POLIERMASCHINE MIT 2 FREQUENZUMRICHTER</b>								
										
INVERTER Nr.2 Volt 400 kW 5,5		E	F	G	G1	dB	kg	NOT INCLUDED	OPTIONAL	
hp	Rpm	E	F	G	G1	dB	kg	Ø mm	ASP.01	
7,5	0 + 1500	1460	1560	1600	1000	75	1150	Ø960 x 100 x Ø45	kW 3	



OPTIONAL  
ASP.04

OPTIONAL  
BAS.01

<b>ART. 132</b>		PULTRICE DA BANCO POLISHING MACHINE FOR DESK POLISSOIR DE BANC POLIERMASCHINE FÜR WERKBANK							
Volt 400 kW 1,1									
hp	Rpm	m/s	dB	E	F	G	G1	kg	
1,5	2800	30	69	590	350	300	175	28	
OPTIONALS									
NOT INCLUDED									
Ø mm	BAS.01	ASP.04							
Ø200x50xØ20	kg 40	kg 45							

<b>ART. 133</b>		SMERIGLIATRICE DA BANCO GRINDING MACHINE FOR DESK MEULE DE BANC SCHEIBENSCHLEIFMASC. FÜR WERKBANK							
Volt 400 kW 1,1									
hp	Rpm	m/s	dB	E	F	G	G1	kg	
1,5	2800	30	69	590	440	300	155	28	
OPTIONALS									
NOT INCLUDED									
Ø mm	BAS.01	ASP.04							
Ø200x25xØ20	kg 40	kg 45							

<b>ART. 134</b>		SMERIGLIATRICE + PULTRICE DA BANCO GRINDING MACHINE + POLISHING MACHINE MEULE + POLISSOIR DE BANC SCHEIBENSCHLEIF-UND POLIERMASCHINE							
Volt 400 kW 1,1									
hp	Rpm	m/s	dB	E	F	G	G1	kg	
1,5	2800	30	69	590	440	300	155	28	
OPTIONALS									
NOT INCLUDED	NOT INCLUDED								
Ø mm	Ø mm	BAS.01	ASP.04						
Ø200x25xØ20	Ø200x50xØ20	kg 40	kg 45						